

Pedal Post Waste Container System Specifications and Carton size

35 Litre Model

Base outside measurements, Width 340mm, Depth 450mm

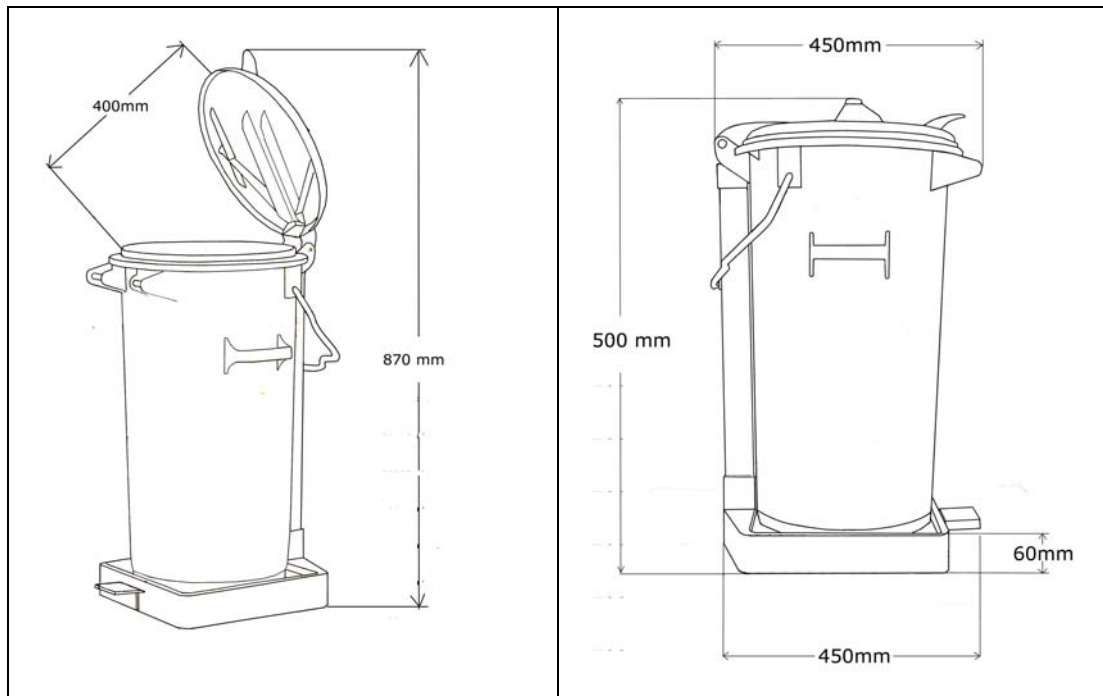

50 Litre Model

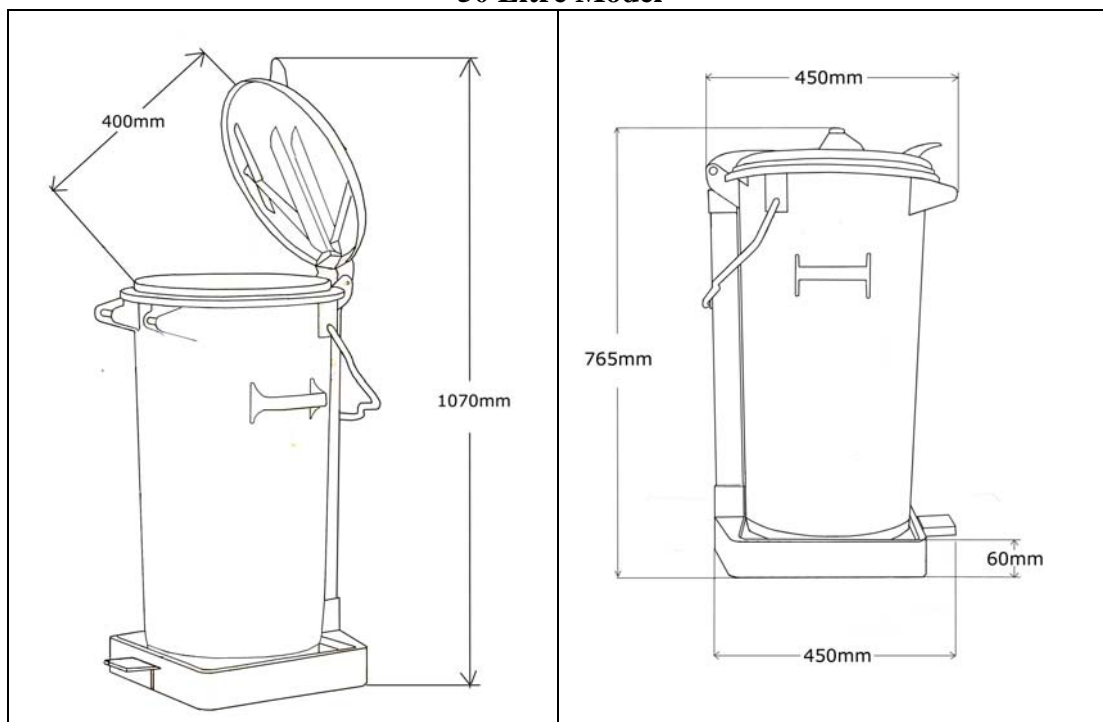

Packaging Sizes, 1 complete unit

Carton Size

35 litre: 460mm x 460mm x 60 mm, weight 6.5 Kgs

50 Litre: 460mm x 460mm x 780 mm, weight 7.5 Kgs