



Pedal Post Hands Free Waste Segregation Container System

Designed specifically for the Health Industry



Manufactured in QLD



Product Details

Quiet, industrial grade container and foot pedal system for hands free sanitary use.

The unit can be supplied with mark resistant castors or rear wheels and T- Bar handle, for ease of mobility.

2 sizes – 50 litre, 35 litre

Can be colour coded to suit your needs or requirements

Tight fitting, overlapping lid with locking handle.

Smooth contours for ease of cleaning

Foot pedal and container are separate units

The Pedal Post waste segregation system has been designed to withstand constant use, year after year.



Features

Large mouth opening of bin

Grab hooks built in, for future automated decanting or automated cleaning

Ultra smooth foot pedal operation, industrial grade

Ultra quiet lid closing, no need for noise dampeners

Smooth contours for ease of cleaning and no sharp corners to mark walls.

Stable Base unit that will not mark floors



Unique Features

Container and Foot Pedal are separate units

Container attaches or detaches from foot pedal unit in seconds.

Locking handle locks lid into place or locks container to foot pedal

Advantages

Ease of cleaning

Containers interchangeable

Container can leave the site no foot pedal attached

If one part is damaged, you are not replacing the whole unit.



Product Models

Can be supplied with rear wheels and T bar handle



This unit is designed to take the waste container to the patient

Emergency departments

Dialysis rooms

Intensive care

Operating rooms



Product Models

Manual lid close model



Labelling on inside of lid and outside of lid

“Close lid Manually”

All models can be supplied with the **manually close lid version**, used in emergency areas if you need the lid of the container to stay open. Depress the foot pedal and the lid stays open for you to manually close.

Product Models

Can be fitted with castors for ease of mobility



Heavy duty mark resistant nylon castors.

Castors are fitted to each internal corner of the base unit

Factory fitted

Castors fitted internally

Labelling & Colour Coding

All labelling & colour codes to suit your needs or requirements



CLINICAL WASTE



NO SHARPS

Clinical Waste	General waste	Cytotoxic waste	General Waste
----------------	---------------	-----------------	---------------

All waste containers are supplied with labelling attached, just let us know your requirements

CLINICAL WASTE



KDL Products
Innovations for the Future



GENERAL WASTE



KDL Products
Innovations for the Future

No Recyclables

CYTOTOXIC WASTE



INCINERATE AT 1100°C

Components

Container injection moulded from specially designed HDPE

Resistant to decay, frost, heat and chemicals

Special UV-stabilisation provides excellent ageing characteristics

Long service life

Moulded handles

High quality materials

Industrial grade foot pedal

Withstands exposure to high mechanical stress levels

Container can be removed from foot pedal unit in seconds

Tight fitting overlapping lid with locking handle

Easily manoeuvred (castors or rear wheels options)

Corrosion resistant steel components



Specifications 35 Litre Model

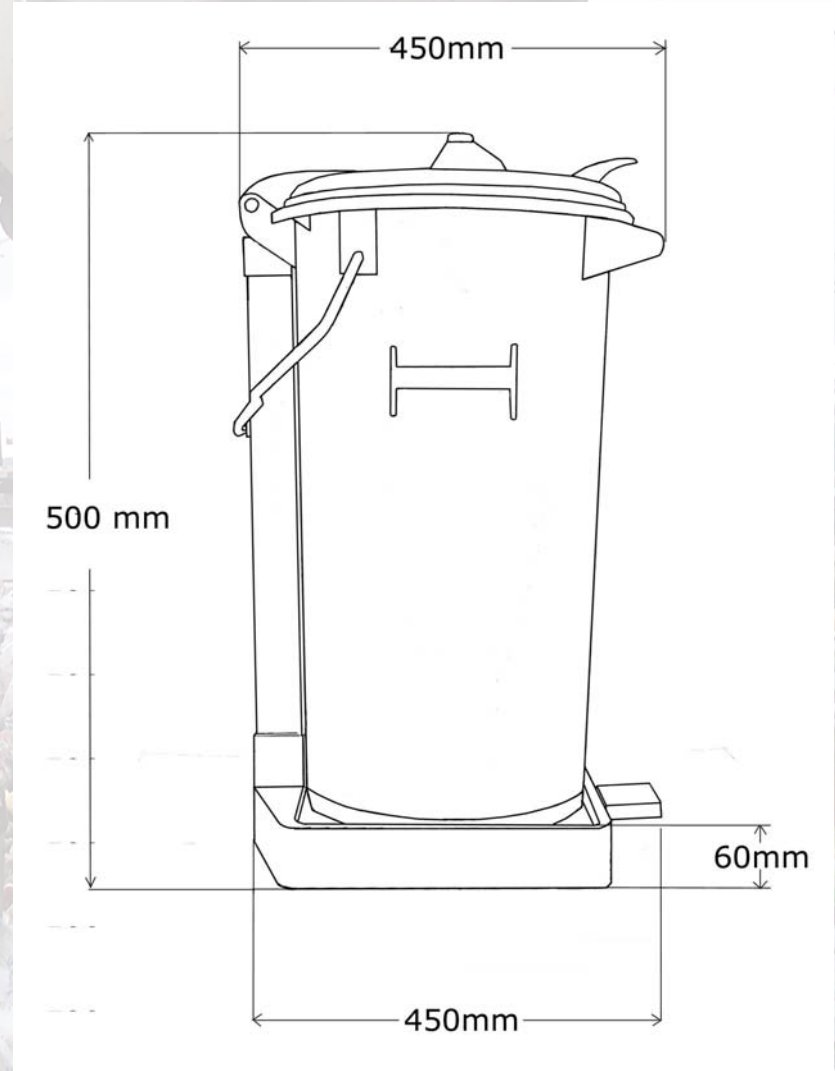
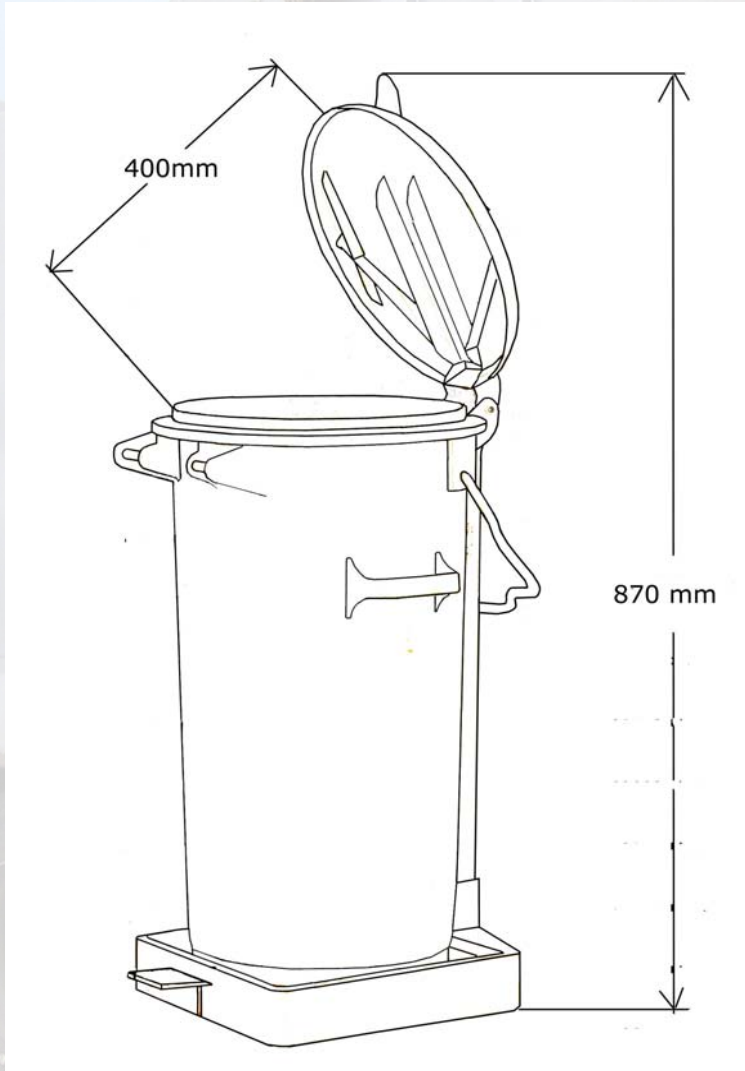

Specifications 50 Litre Model

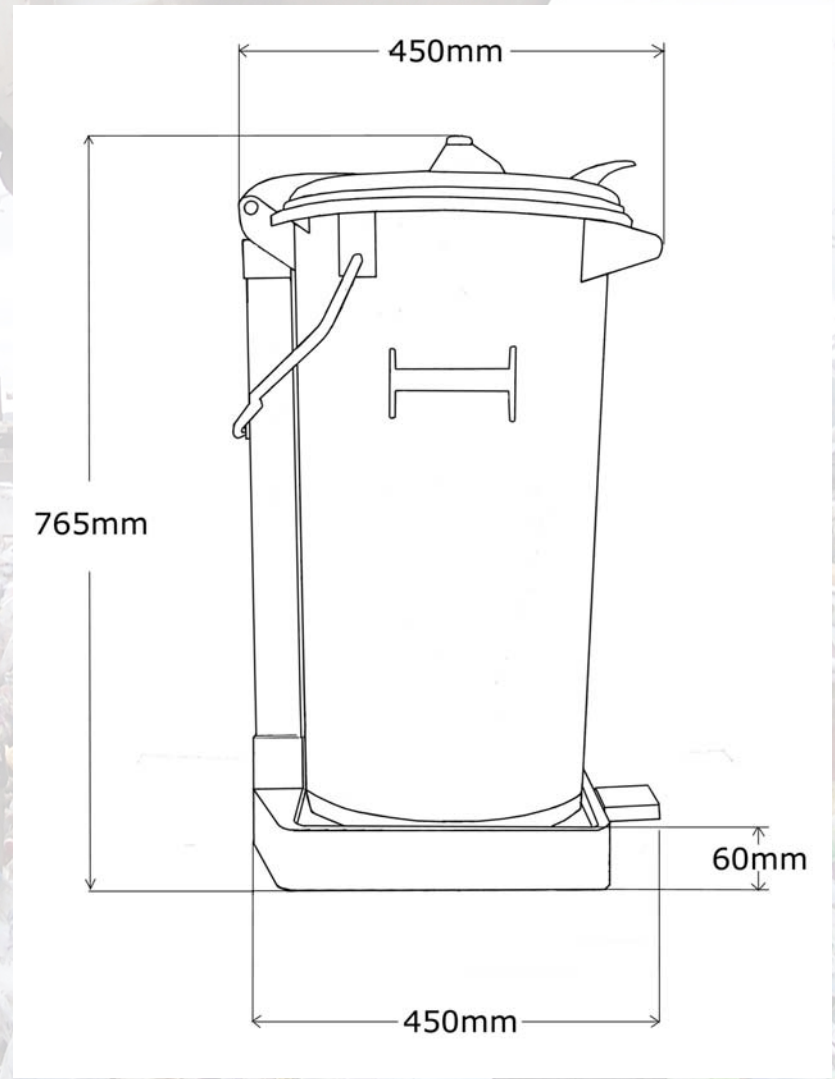
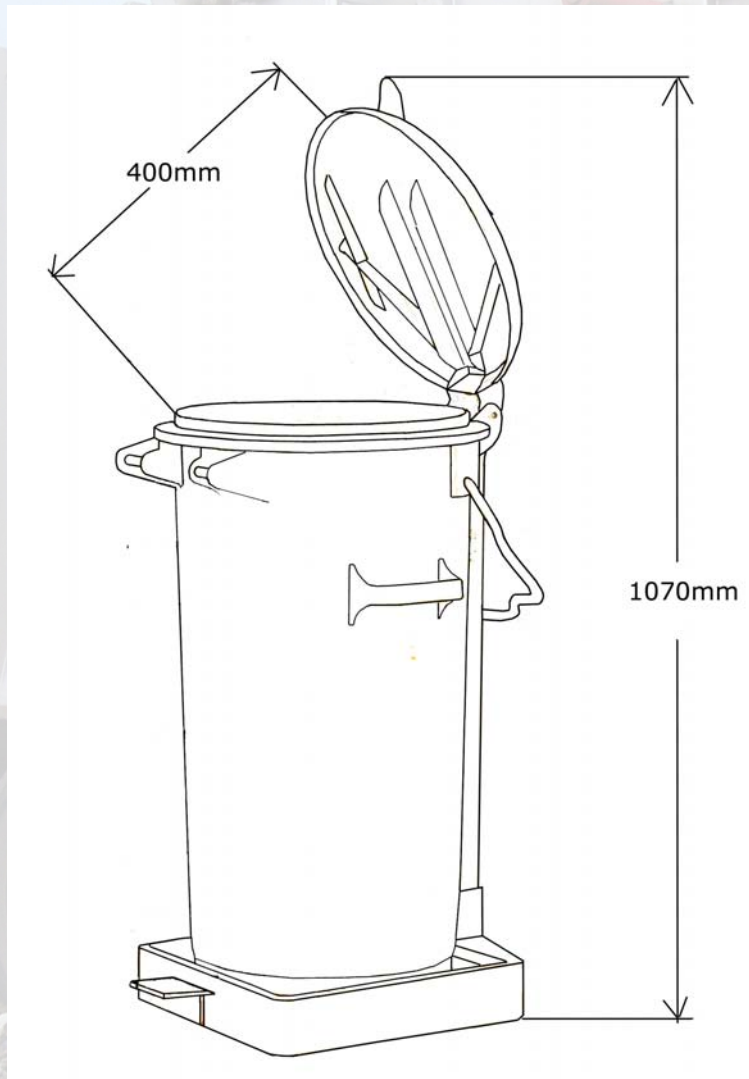

For more information

Contact

Kevin Lansdown

KDL Products Pty Ltd

Phone: 07 55391704

Fax: 07 55391709

Mobile: 0412878414 (Kevin)

Email: kevin@kdlproducts.com

Web sites: www.kdlproducts.com

www.wasteeducation.com